

Product Brief

Intel® Xeon® Processor E3 Family

Entry-Level Workstation

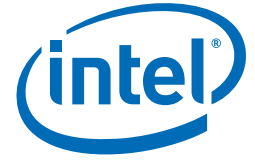

Intel® Xeon® Processor E3 Family for Entry-Level Workstation

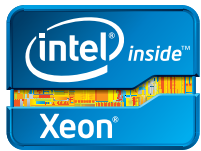

Invest in your professional creativity.
Step up to intelligent performance
and optimized graphics.

The Intel® Xeon® processor E3 family with the new Intel® HD Graphics P3000, a processor-based graphics technology, revolutionizes the way workstation users gain access to the graphics performance and features they need to build, test and visualize their creative ideas. Coupled with advancements in performance, bandwidth, smart cache and energy-efficient technologies, Intel Xeon processor E3 family-based workstations will help users to work with complex 3D designs that once required investments in discrete technologies.

Intelligent Performance for Digital Content Creation

Entry-level workstations based on the Intel Xeon processor E3 family come with a suite of technologies that help to deliver a workstation experience that collectively improve performance and reliability.

Intel® Turbo Boost Technology 2.0¹ recognizes when a workstation is underutilized and redirects performance to where it can benefit the user the most. Intel® Turbo Boost Technology 2.0 dynamically helps users who need fewer cores but higher frequencies to improve either processor or graphics performance. If neither is needed, Intel Turbo Boost Technology 2.0 helps improve the workstation's energy efficiency.

Intel® HD Graphics P3000², available on entry-level workstations based on the Intel Xeon processor E3 family, delivers optimized graphics, often eliminating the need for third-party graphic cards, and delivering the graphics performance and quality demanded by many CAD and media and entertainment applications.

Serial ATA (SATA) 3.0 technology available on entry-level workstations built into the Intel Xeon processor E3 family doubles the data transfer rate to 6.0 Gbps and delivers a number of improved

features while remaining completely backward-compatible with existing drives, controllers, connectors, and cables. Intel Xeon processor E3 family-based systems with affordable solid state drives (SSDs) installed use less power than those with hard disk drives, and deliver data faster and with higher reliability.

A Smart Investment in Enhanced Manageability, Security, and Reliability

Intel® vPro™ Technology: Entry-level workstations based on the Intel Xeon processor E3 family now include Intel vPro Technology, a broad set of manageability and security features that make it easier for IT to secure and manage your workstation.³ This means IT can now remotely configure, diagnose, and repair your workstation even if it's unresponsive, so you can be up and running more quickly.⁴ It also means your workday won't be disrupted with patches and updates as IT can now do that during off hours.⁵ With Intel vPro Technology, your business can improve costs and increase efficiency by taking advantage of intelligent performance and unique hardware-assisted security and manageability features.³

Error-Correcting Code Memory (ECC Memory): In addition, all Intel Xeon processor-based workstations support ECC Memory, which is typically only found on high-end systems. ECC Memory automatically detects and corrects up to 99.9998 percent of memory errors to improve data integrity and system uptime. Since the probability of data errors increases with the size of memory footprints, this is an essential feature for anyone working with large and complex designs.

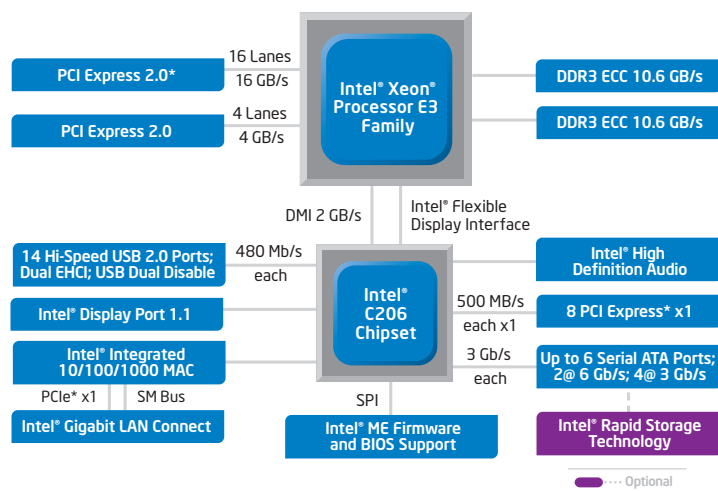

Product Name	Features
Intel® HD Graphics P3000 ²	<ul style="list-style-type: none"> Graphics certified with third-party vendors including Autodesk AutoCAD,* Inventor,* and Adobe CS4,* among others.
Intel® Turbo Boost Technology 2.0 ¹	<ul style="list-style-type: none"> Increases performance when you need it most, by increasing core frequencies beyond rated values for peak workloads.
Intel® Advanced Vector Extensions (Intel® AVX)	<ul style="list-style-type: none"> Increases floating-point computation capabilities. Improves workstation performance of applications ranging from image, video, and audio processing applications to 3D modeling.
Intel® Virtualization Technology ⁵	<ul style="list-style-type: none"> Enables IT to create virtual partitions – while a user is working – in order to load patches, fixes and update. Systems are no longer taxed with IT burdens during critical project times.
Intel® Advanced Encryption Standard New Instructions (Intel® AES-NI) ⁶	<ul style="list-style-type: none"> Adds new instructions to accelerate data encryption and decryption.
Intel® Smart Cache Technology	<ul style="list-style-type: none"> Improves Intel® Xeon® processor-based workstation performance and efficiency by increasing the probability that each execution core can access data from a higher-performance, more-efficient cache subsystem.

Learn More

Visit www.intel.com/go/workstation for more information and resources.

¹ Requires a system with Intel® Turbo Boost Technology capability. Intel Turbo Boost Technology 2.0 is the next generation of Turbo Boost Technology and is only available on select Intel® processors. Consult your PC manufacturer. Performance varies depending on hardware, software, and system configuration. For more information, visit <http://www.intel.com/go/turbo>.

² Requires a system with Intel® HD Graphics P3000 capability. Intel® HD Graphics P3000 is only available on select Intel® processors. Consult your PC manufacturer.

³ Intel® vPro™ Technology is sophisticated and requires setup and activation. Availability of features and results will depend upon the setup and configuration of your hardware, software, and IT environment. To learn more visit: <http://www.intel.com/technology/vpro/>.

⁴ Requires activation and a system with a corporate network connection, an Intel® AMT-enabled chipset, network hardware, and software. For notebooks, Intel AMT may be unavailable or limited over a host OS-based VPN, when connecting wirelessly, on battery power, sleeping, hibernating, or powered off. Results dependent upon hardware, setup, and configuration. For more information, visit <http://www.intel.com/technology/platform-technology/intel-amt>.

⁵ Intel® Virtualization Technology requires a computer system with an enabled Intel® processor, BIOS, and virtual machine monitor (VMM). Functionality, performance or other benefits will vary depending on hardware and software configurations. Software applications may not be compatible with all operating systems. Consult your PC manufacturer. For more information, visit <http://www.intel.com/go/virtualization>.

⁶ Intel® AES-NI requires a computer system with an AES-NI-enabled processor, as well as non-Intel software to execute the instructions in the correct sequence. AES-NI is available on select Intel® processors. For availability, consult your system manufacturer. For more information, see <http://software.intel.com/en-us/articles/intel-advanced-encryption-standard-instructions-aes-ni/>.

Intel may make changes to specifications and product descriptions at any time, without notice. Designers must not rely on the absence or characteristics of any features or instructions marked "reserved" or "undefined." Intel reserves these for future definition and shall have no responsibility whatsoever for conflicts or incompatibilities arising from future changes to them. The information here is subject to change without notice. Do not finalize a design with this information. The products described in this document may contain design defects or errors known as errata which may cause the product to deviate from published specifications. Current characterized errata are available on request. Contact your local Intel sales office or your distributor to obtain the latest specifications and before placing your product order. Copies of documents which have an order number and are referenced in this document, or other Intel literature, may be obtained by calling 1-800-548-4725, or by visiting Intel's Web Site www.intel.com/.

Copyright © 2011 Intel Corporation. All rights reserved. Intel, the Intel logo, Xeon, and Xeon inside are trademarks of Intel Corporation in the U.S. and other countries.

*Other names and brands may be claimed as the property of others.

